

PostLab 2: Code of Arms

Problems

1. System (Transfer) Function

In Lab 2 (Code of Arms), we studied a propellor arm system that is controlled by a PD or PID controller. The system block diagram is shown below:

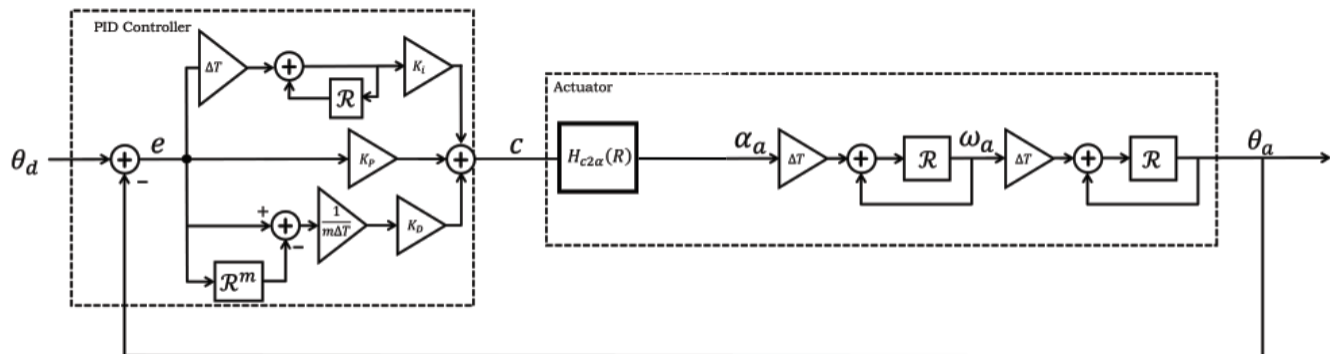

Determine the system function (aka transfer function) for this block diagram as follows. Express your answers in terms of the operator \mathcal{R} .

1a. Let $C = K(\mathcal{R})E$. Determine an expression for $K(\mathcal{R})$ in terms of the controller constants K_p , K_d , K_i , and m as well as the step size ΔT .

$$K(\mathcal{R}) = \boxed{\phantom{K(\mathcal{R}) = \text{[expression]}}}$$

1b. Let $A_a = H_{c2a}(\mathcal{R})C$. Determine an expression for H_{c2a} for the "Non-Instant" motor model from part 7 of the lab.

$$H_{c2a}(\mathcal{R}) = \boxed{\phantom{H_{c2a}(\mathcal{R}) = \text{[expression]}}}$$

1c. Let $\Theta_a = H_{a2\theta}(\mathcal{R})A$. Determine $H_{a2\theta}$.

$$H_{a2\theta}(\mathcal{R}) = \boxed{\phantom{H_{a2\theta}(\mathcal{R}) = \text{[expression]}}}$$

1d. Let $\Theta_a = H_c(\mathcal{R})\Theta_d$, where $H_c(\mathcal{R})$ represents the "closed-loop" transfer function. Determine $H_c(\mathcal{R})$ in terms of $K(\mathcal{R})$, $H_{c2a}(\mathcal{R})$, and $H_{a2\theta}(\mathcal{R})$.

$$H_c(\mathcal{R}) = \boxed{\phantom{H_c(\mathcal{R}) = \text{[expression]}}}$$

2. Step Responses

Compare the step responses of the PD and PID systems as follows. Set the input $\theta_d[n]$ to a unit step signal

$$\theta_d[n] = \begin{cases} 1 & \text{if } n \geq 0 \\ 0 & \text{otherwise} \end{cases}$$

Then use your favorite computer language to compute the step response under the following conditions.

2a. PD controller. Set $K_i = 0$ and use the control parameters that you used in lab. Paste a plot of the step response in the box below.

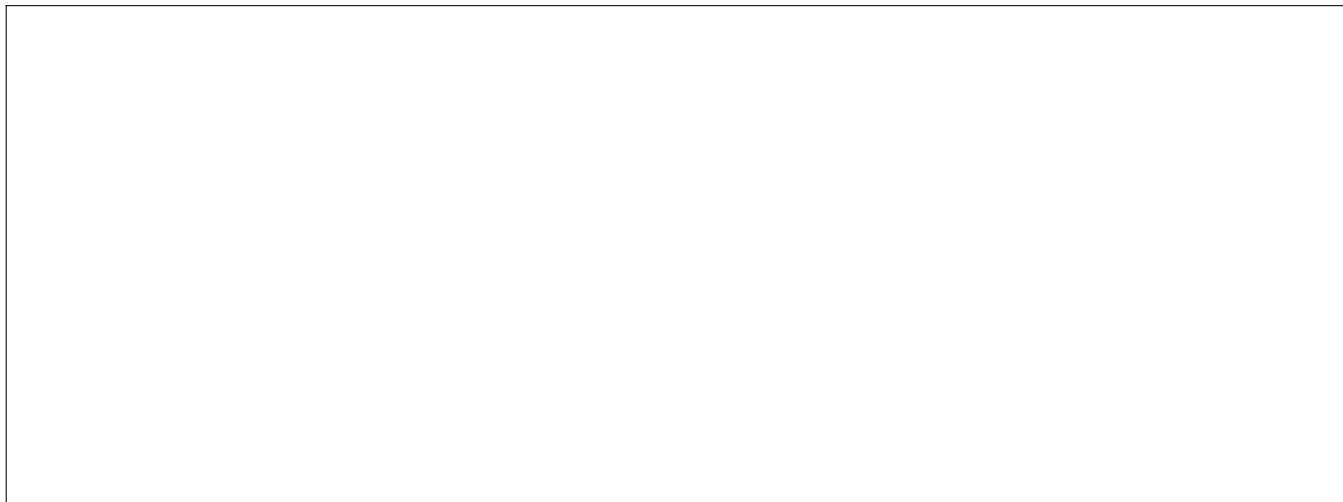

What is the steady-state error of this system?

steady-state error =

2b. PID controller. Now set K_i to the value you used in lab and calculate the response with a PID controller.

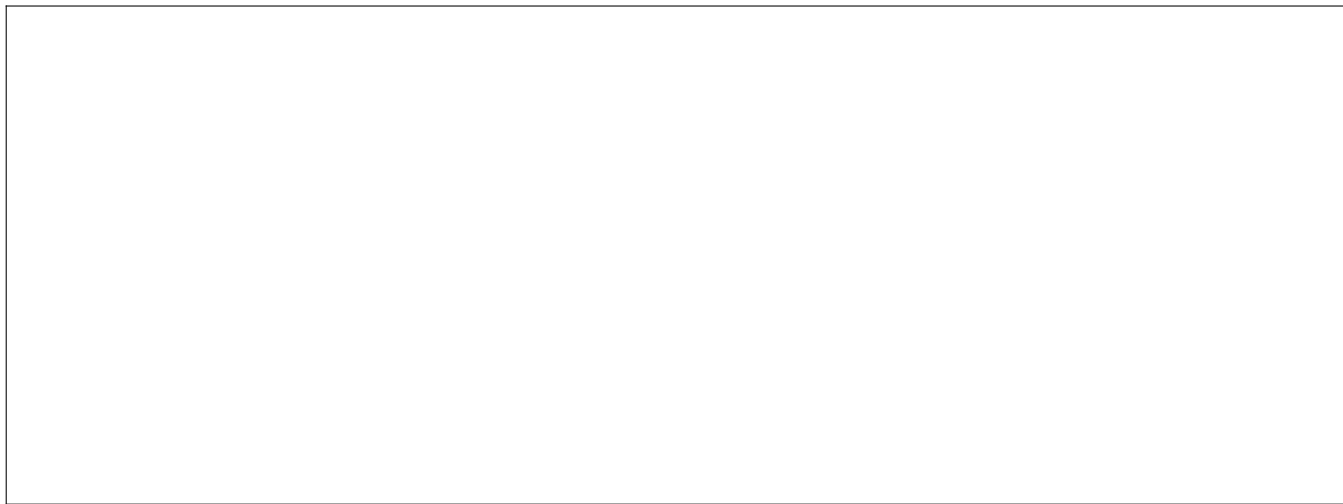

What is the steady-state error of this system?

steady-state error =

3. Disturbance Measurements

From a modeling point of view, adding the integral term doesn't help much for this system. However, the integral term helps significantly when dealing with disturbances. You have collected data when a weight is dropped onto the propellor arm. Let's compare the disturbance rejection properties for the PD and PID controllers.

3a. Show the experimental data of your PD controller when a weight is added.

3b. Show the experimental data of your PID controller when a weight is added.

3c. Which controller provides better disturbance rejection?

PD or PID:

4. Disturbance Model

We can model the effect of the disturbance by adding a new input pathway as shown below.

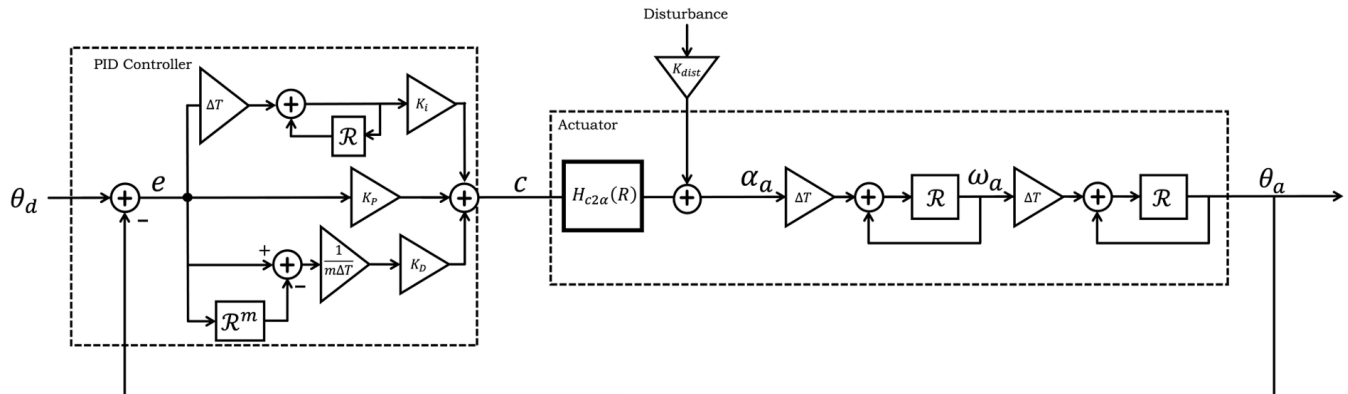

Determine the disturbance transfer function H_{dist} as follows

$$\Theta_a = H_{dist}(\mathcal{R})M_{dist}$$

where M_{dist} represents the disturbance input. When you write the disturbance transfer function, you can set the other input Θ_d to 0.

4a. Derive the disturbance transfer function.

Implement this disturbance function in your favorite programming language. Simulate the system disturbance rejection with a PD controller and PID controller. In the simulations, you can model dropping a weight as a step function. Use $K_{dist} = 10$.

4b. Disturbance rejection with a PD controller.

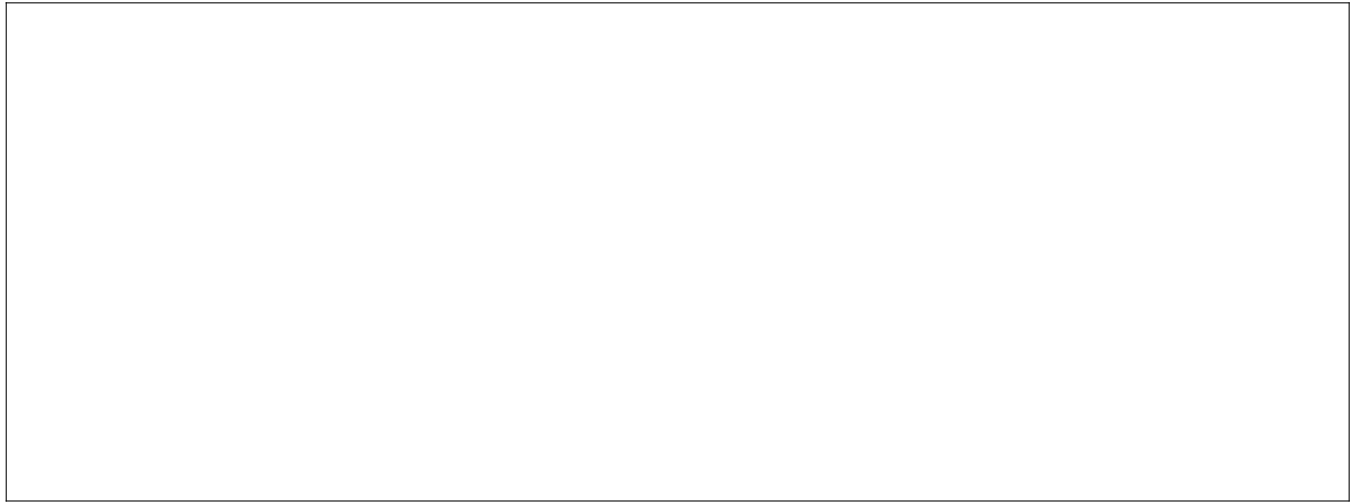

4c. Disturbance rejection with a PID controller.

